

## QUALITY INDUSTRIAL TOOLING

### Bar Turning Tools

- Tip material: Carbide
- Carbide grade: P30
- Clearance angle: 6°
- Suitable for heavy duty turning and boring on all classes of steel
- Suitable also for interrupted cutting and machining at low speeds and heavy feeds
- Manufactured to ISO DIN BHMA



Left Hand

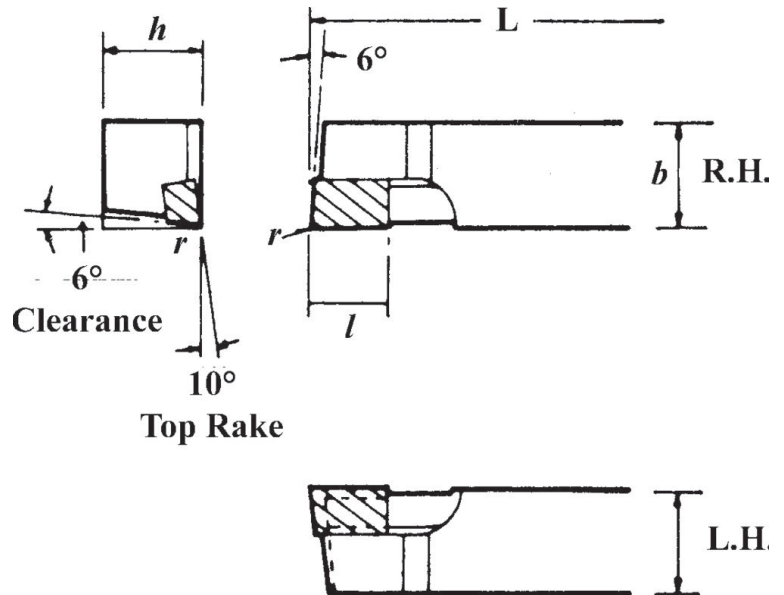

Tool No.	Shank Height (in.)	Shank Width (in.)	Length (in.)	Weight (g)	Cutting Direction	Order Code
100	3/8	3/8	3-1/2	70	Right Hand	KEN-100-2010K
101	3/8	3/8	3-1/2	70	Left Hand	KEN-100-2040K
102	1/2	1/2	4	120	Right Hand	KEN-100-2060K
103	1/2	1/2	4	120	Left Hand	KEN-100-2100K
106	5/8	5/8	5	260	Right Hand	KEN-100-2180K
107	5/8	5/8	5	260	Left Hand	KEN-100-2230K
110	3/4	3/4	5-1/2	440	Right Hand	KEN-100-2280K
111	3/4	3/4	5-1/2	440	Left Hand	KEN-100-2300K
116	1	1	6-1/2	810	Right Hand	KEN-100-2410K